

# REDUTORES A ENGRENAGENS HELICOIDAIS LINHA 2000

## FLANGE PARA MOTORES

FORMA CONSTRUTIVA 1 A 9

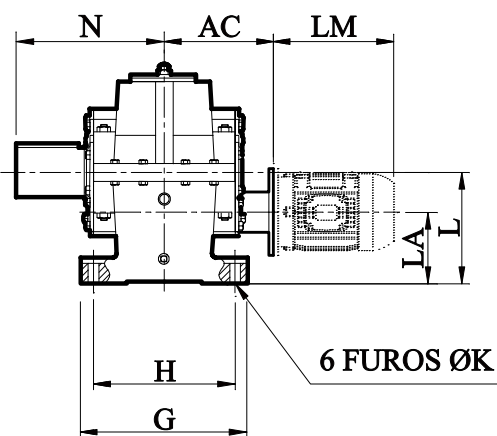

FORMA CONSTRUTIVA 10

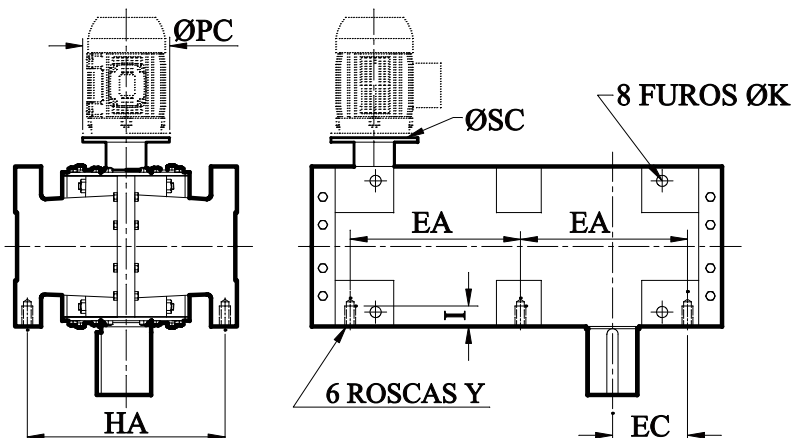

REDUTOR TIPO	MOTOR		N	FLANGE "A" OU "C-DIN"	FLANGE TIPO "F" COM ACOPLAMENTO ELÁSTICO	AC	PC	SC	FORMA 10				
	CARCAÇA	LM							HA	EA	EC	Y	I
H2552	225*	667	438	—	FF400-2552	482	450	19	454	424	194	M24	50
	250*	753		—	FF500-2552	486	550	19					
	280*	902		—	FF500-2552	486	550	19					
132	411	C200-2553		246	200	15							
160	533	A300-2553		270	350	19							
180	571	A300-2553		270	350	19							
200*	627	—		FF350-2553	444	400	19						
90	276	—		250	140	12							
100/112	328	C140-2554		250	160	15							
132	411	C160-2554		250	200	15							
225	667	C200-2554		250	200	15							
250	753	A400-2852		288	450	19							
280*	902	A500-2852		290	550	19							
315*	986	—		507	550	19							
160	533	A300-2853		530	660	24							
180	571	A300-2853	302	350	19								
200*	627	—	302	350	19								
225*	667	—	FF350-2853	471	400	19							
100/112	328	—	FF400-2853	474	450	19							
132	411	A215-2854	260	160	19								
160	533	C200-2854	264	200	15								
280*	902	A300-2854	264	350	19								
315*	986	—	578	550	19								
200*	627	—	608	660	24								
225*	667	A350-3203	298	400	19								
250*	753	—	519	450	19								
100/112	328	—	522	550	19								
132	411	—	292	160	15								
160	533	A215-3204	292	200	15								
280*	902	A265-3204	323	350	19								
315*	986	A300-3204	613	550	19								
355*	1256	—	643	660	24								
160	533	—	683	800	24								
180	571	A300-3653	343	350	19								
200*	627	A300-3653	343	350	19								
225*	667	A350-3653	354	400	19								
250*	753	—	571	450	19								
100/112	328	—	574	550	19								
132	411	A215-3654	325	160	15								
160	533	A265-3654	325	300	15								
180	571	A300-3654	357	350	19								
315*	986	A300-3654	357	350	19								
355*	1256	—	698	660	24								
225*	667	—	743	800	24								
250*	753	—	620	450	19								
280*	902	—	626	550	19								
315*	986	—	661	660	24								
355*	1256	—	736	800	24								
160	533	A300-4104	405	350	19								
180	571	A300-4104	405	350	19								
200*	627	A350-4104	405	400	19								
225*	667	A400-4104	405	450	19								
250*	753	—	638	550	19								
280*	902	—	638	550	19								
315*	986	—	FF500-4104	638	550	19							
355*	1360	—	FF600-4602	812	660	24							
250*	753	—	FF740-4602	812	800	24							
280*	902	—	FF500-4603	698	550	19							
315*	986	—	FF500-4603	698	550	19							
355*	1256	—	FF600-4603	724	660	24							
225*	667	A400-4604	767	800	24								
250*	753	—	464	450	19								
280*	902	—	688	550	19								
315*	986	—	698	550	19								
355*	1360	—	698	550	19								
315*	986	—	FF500-4604	688	550	19							
355*	1360	—	FF500-4604	698	550	19							
315*	986	—	FF600-4604	718	660	24							
355*	1360	—	FF600-5102	840	660	24							
315*	986	—	FF740-5102	880	800	24							
355*	1360	—	880	800	24								
315*	986	—	FF600-5103	800	660	24							
355*	1360	—	FF740-5103	820	800	24							
315*	986	—	820	800	24								
355*	1360	—	777	660	24								
315*	986	—	777	660	24								
355*	1360	—	777	800	24								

\* SOMENTE NA FC 10

INFORMAÇÕES SUJEITAS A ALTERAÇÕES SEM AVISO PRÉVIO